

Top Level

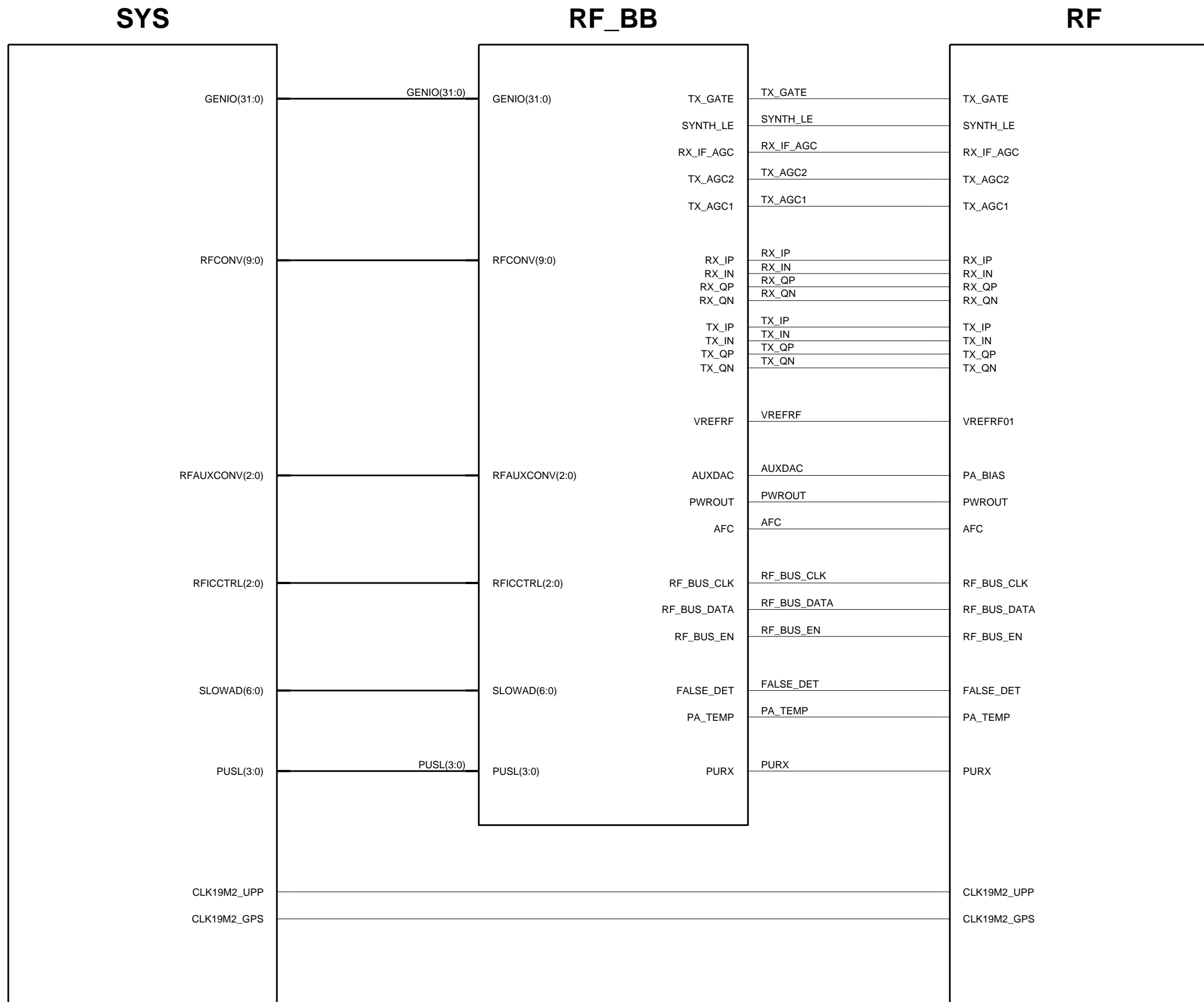

Baseband - Top Level

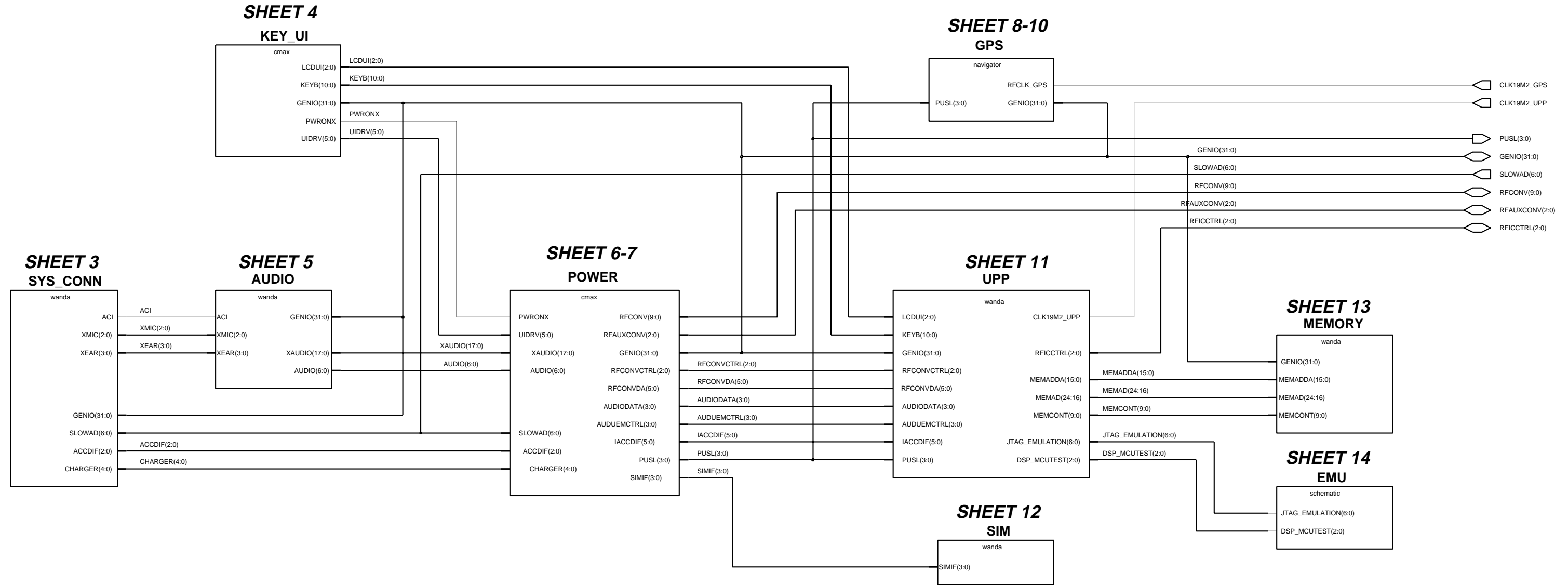

System Connector

BATTERY CONNECTOR



BOTTOM CONNECTOR

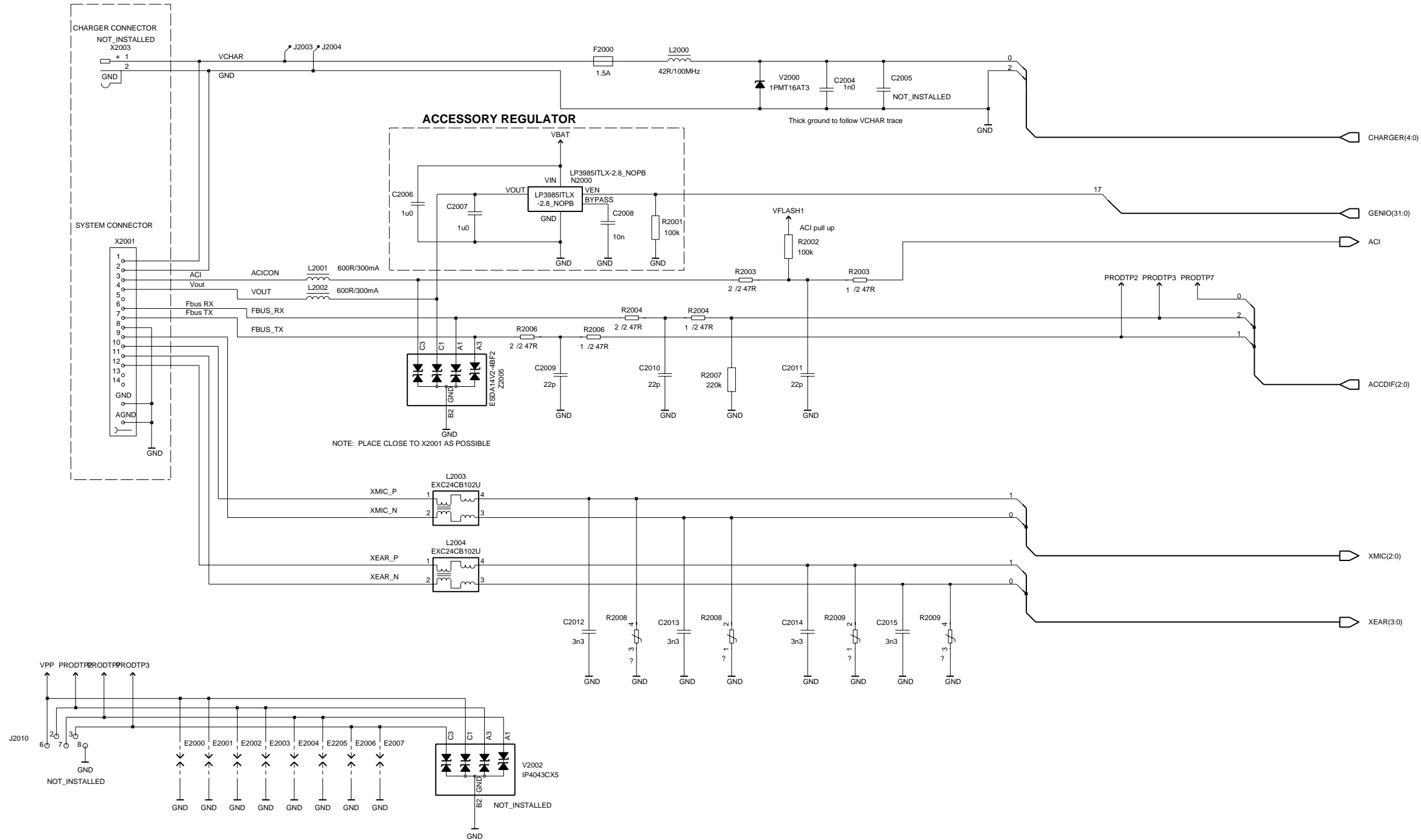

User Interface

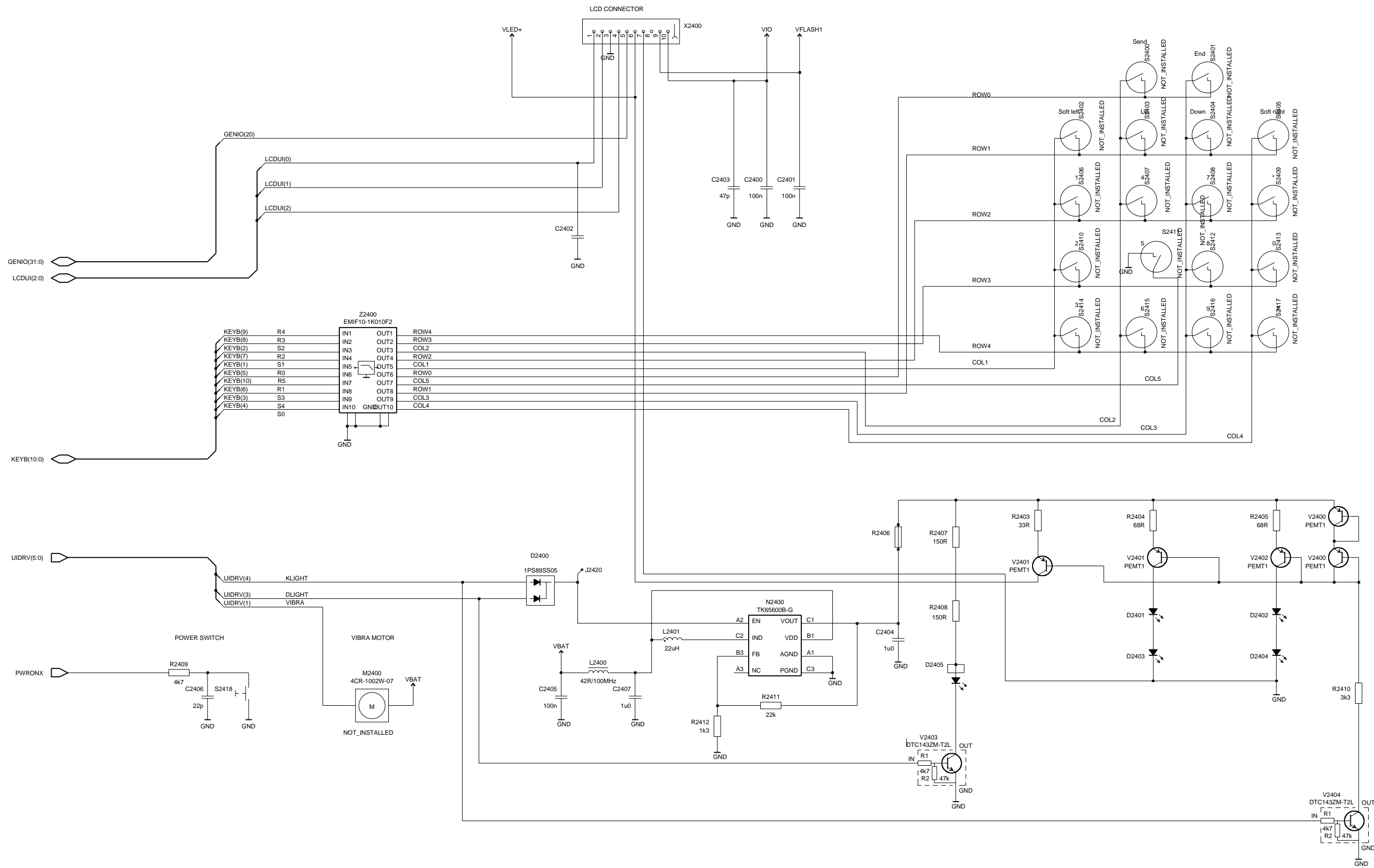

Audio

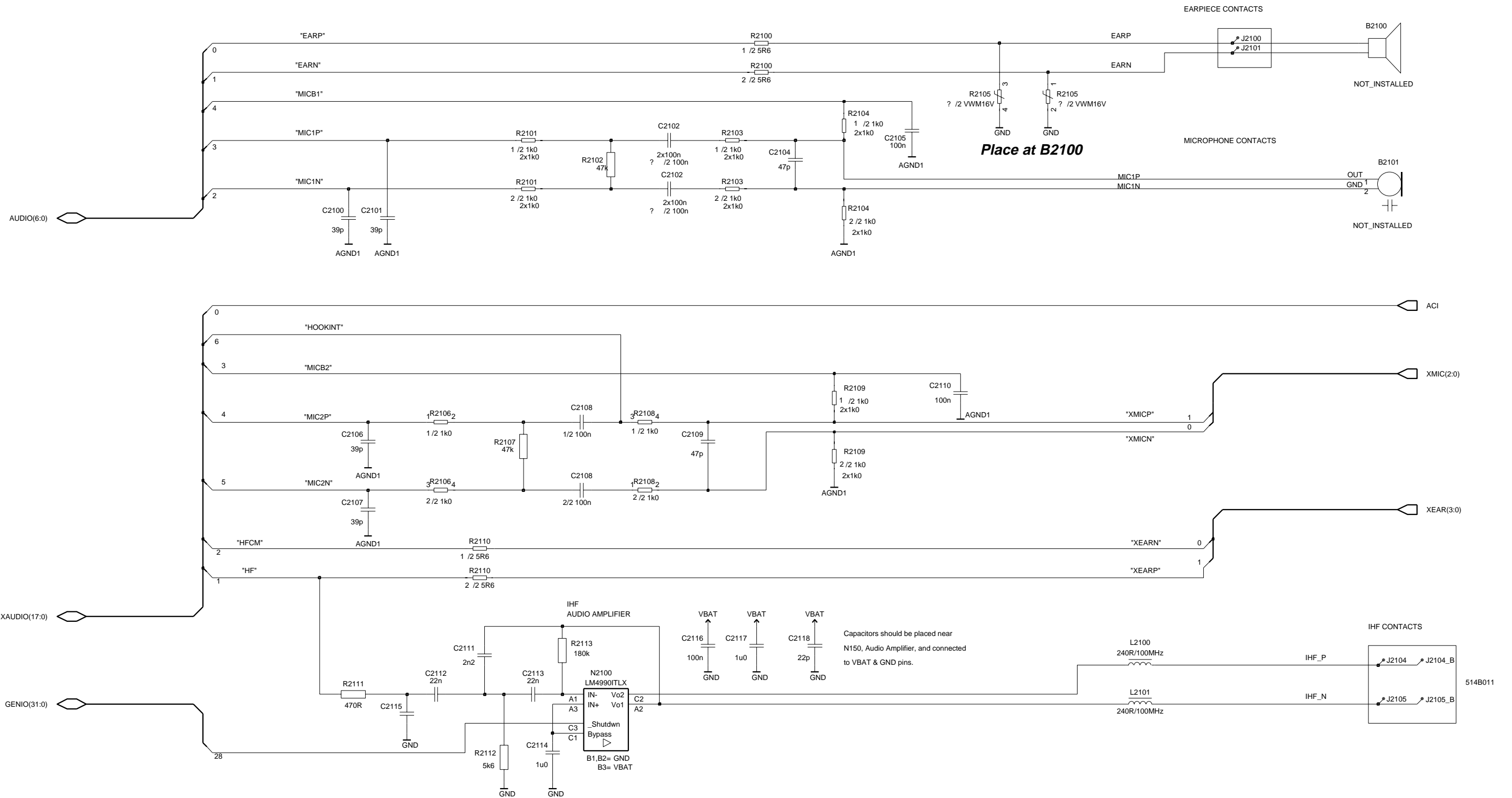

SIM Connector

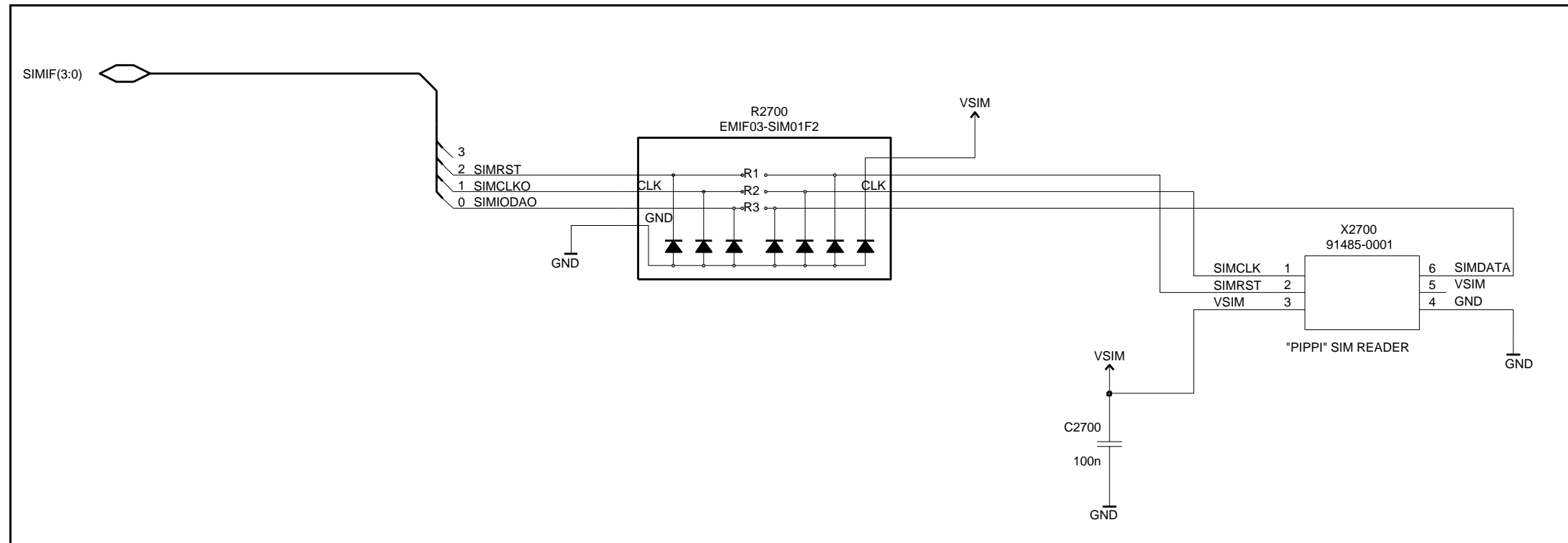

DC/DC Converter

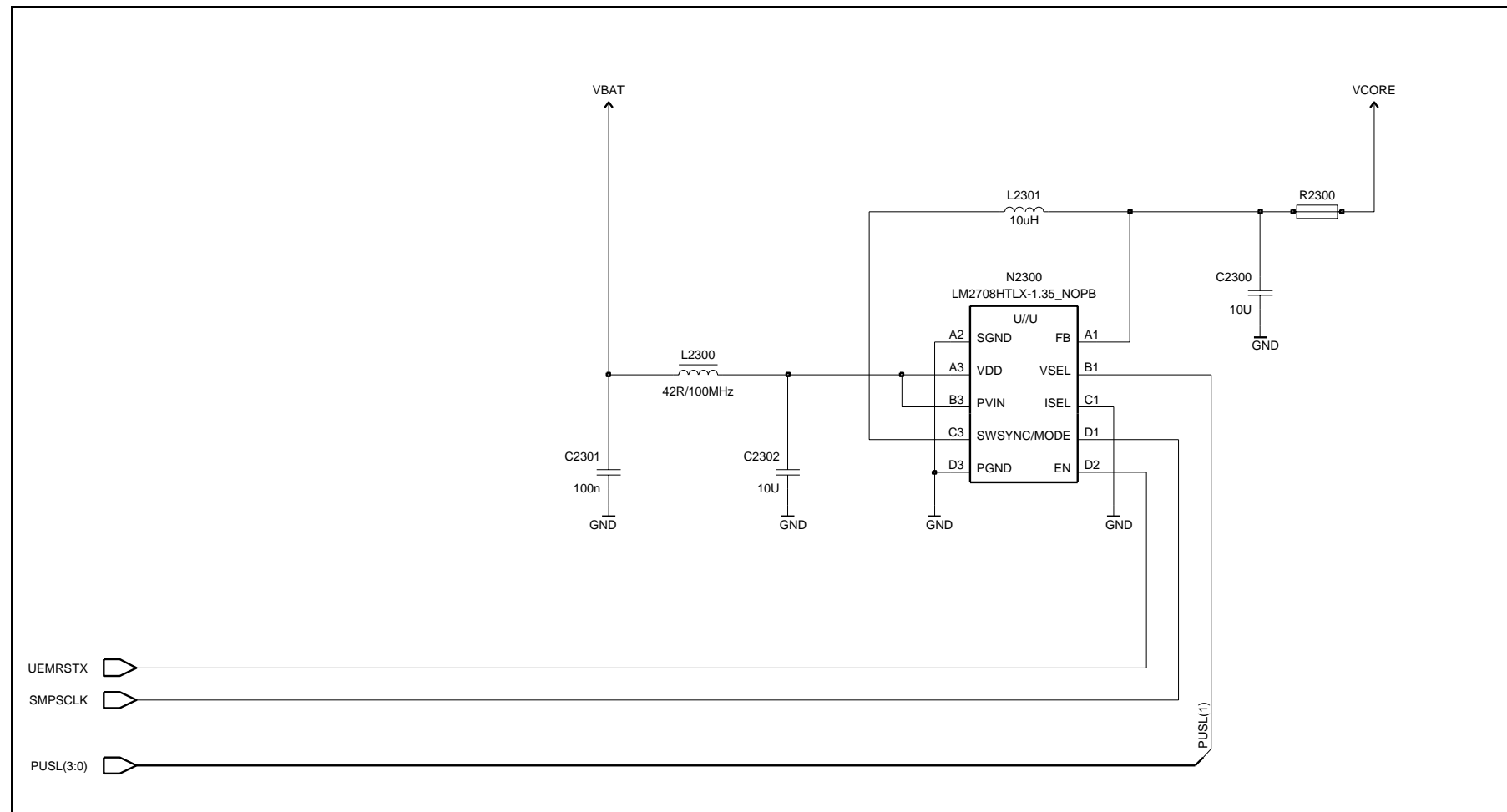

Power

SHEET 6

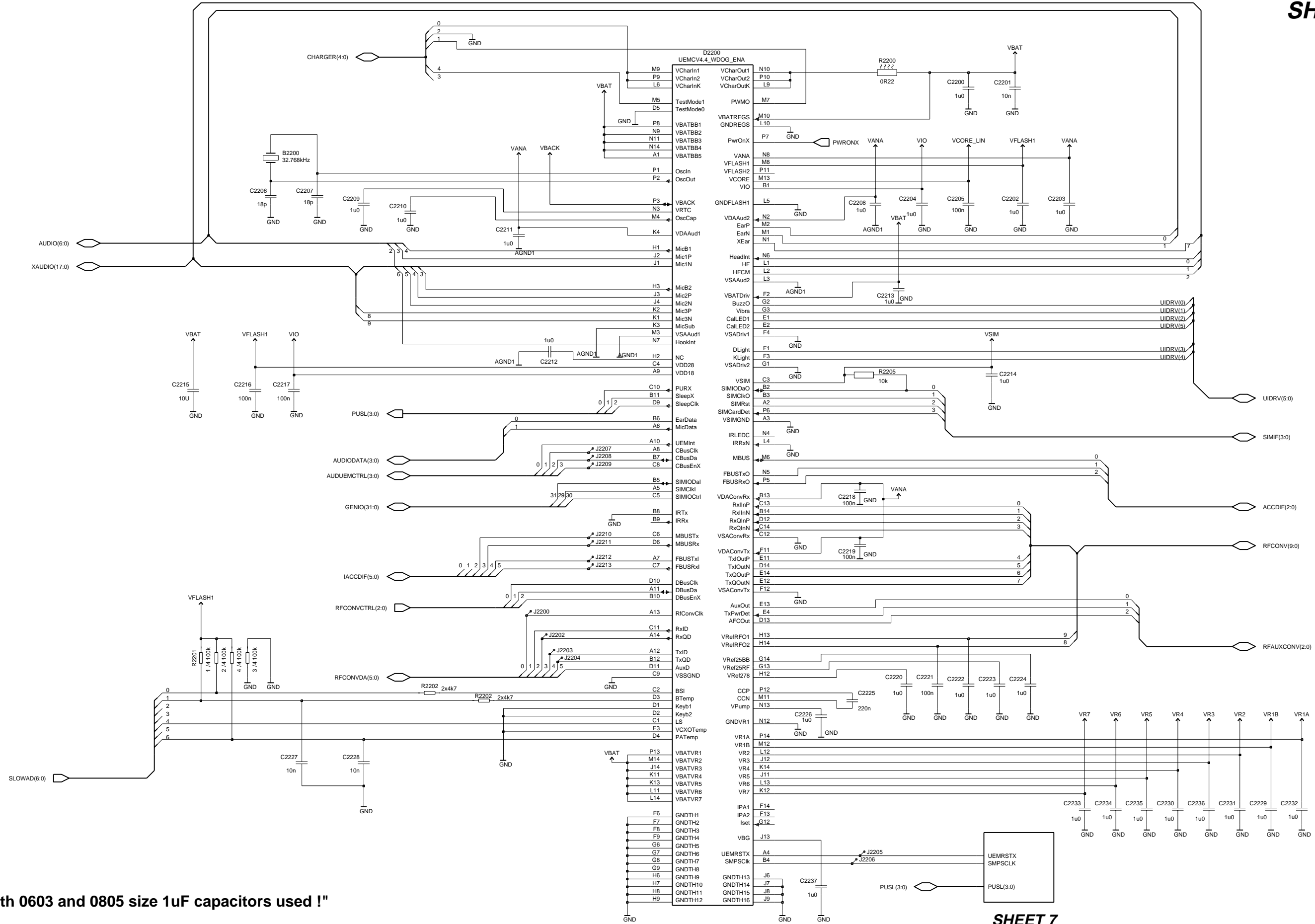

"Both 0603 and 0805 size 1uF capacitors used !"

SHEET 7

UPP

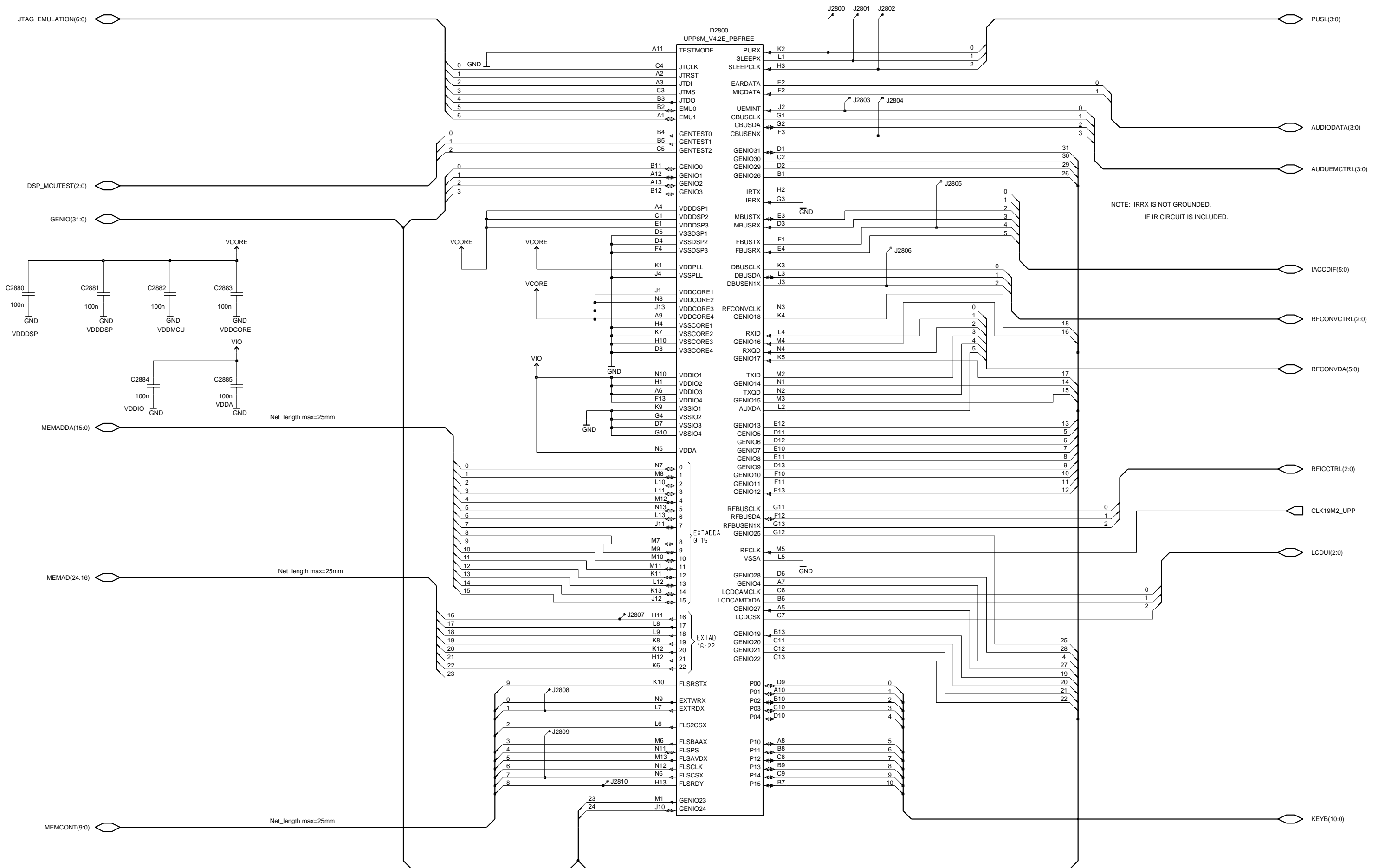

RF-BB Interface

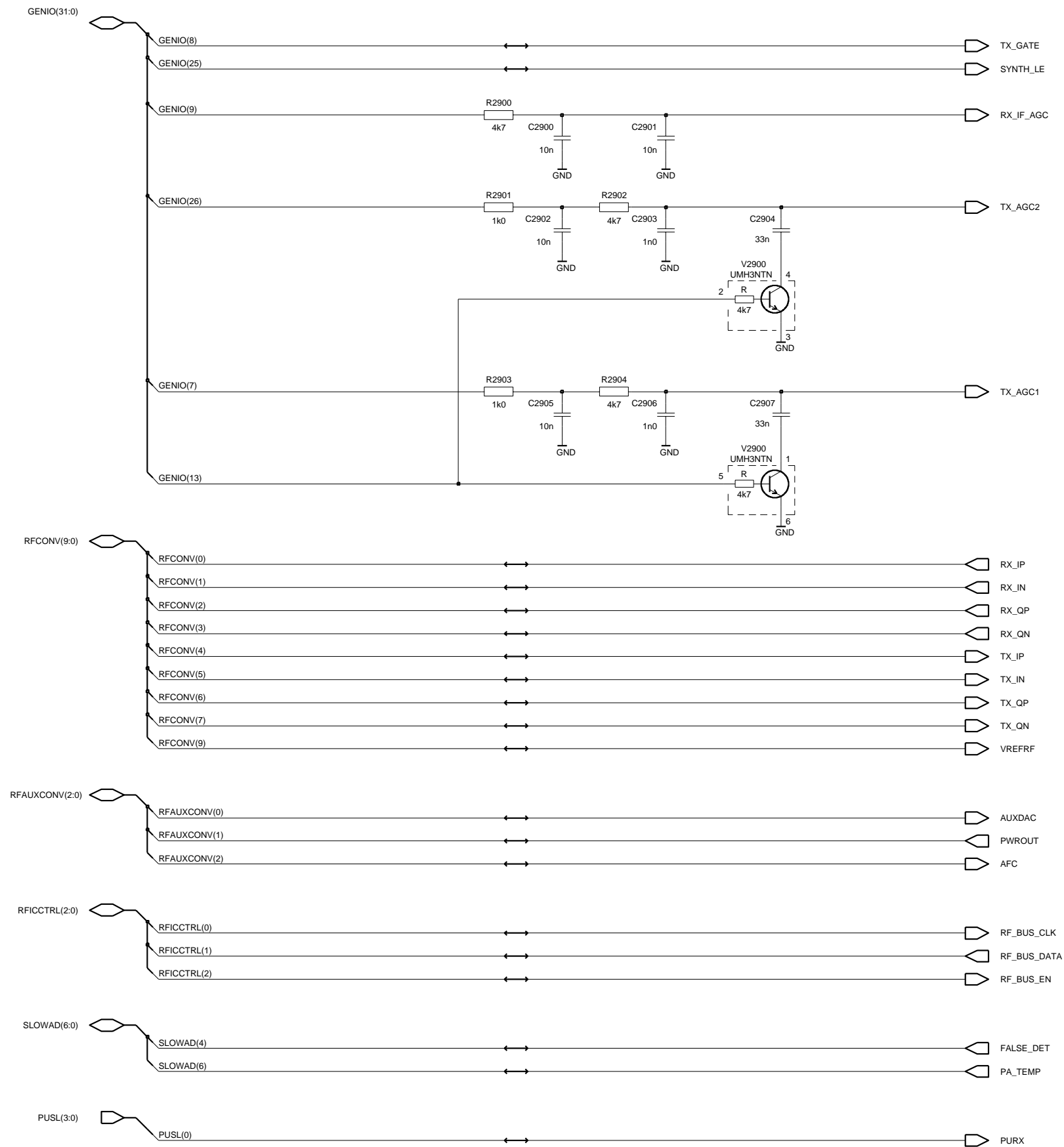

Memory

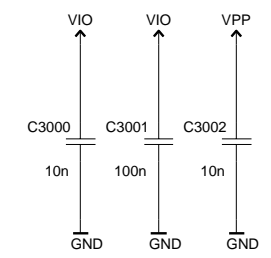
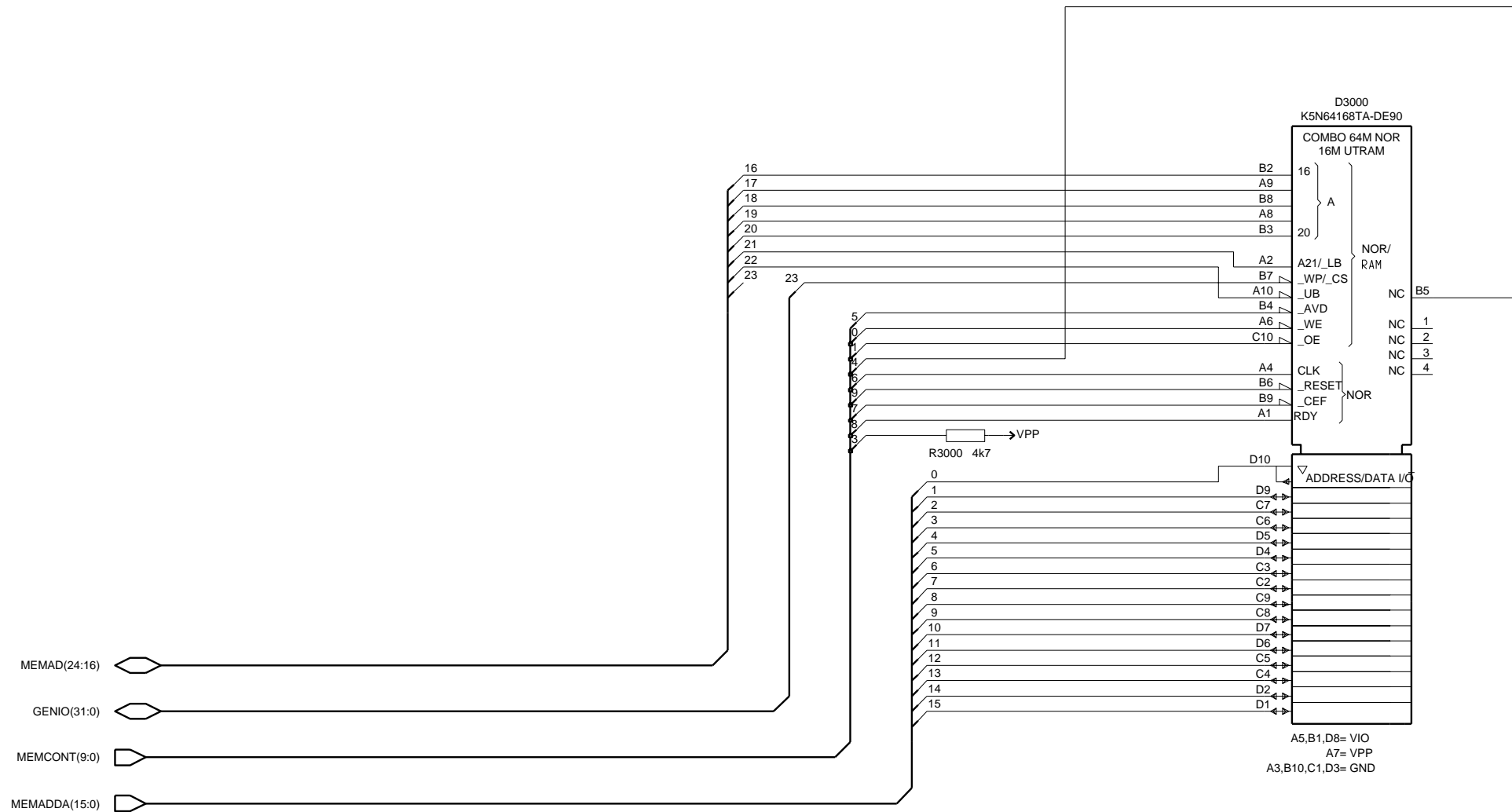

JTAG and Ostrich Connectors

JTAG

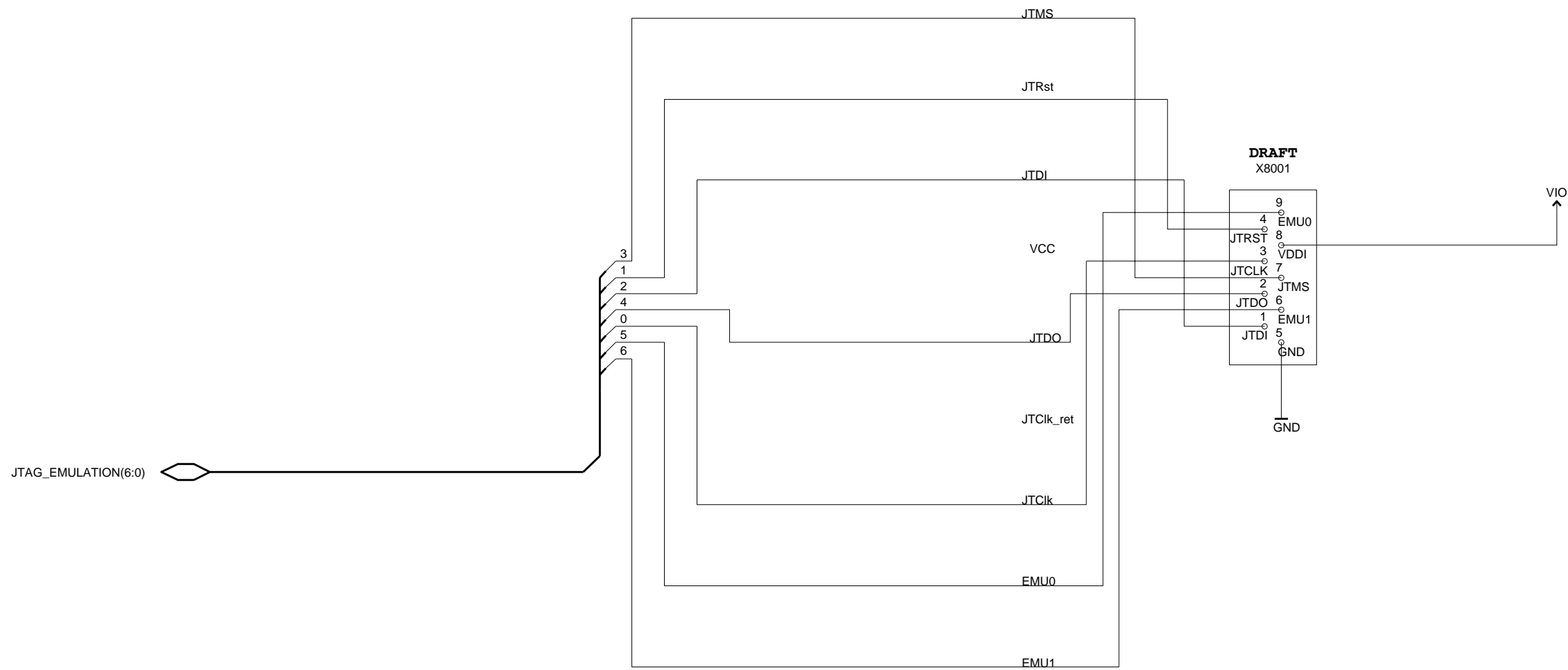

OSTRICH



RF - Top Level

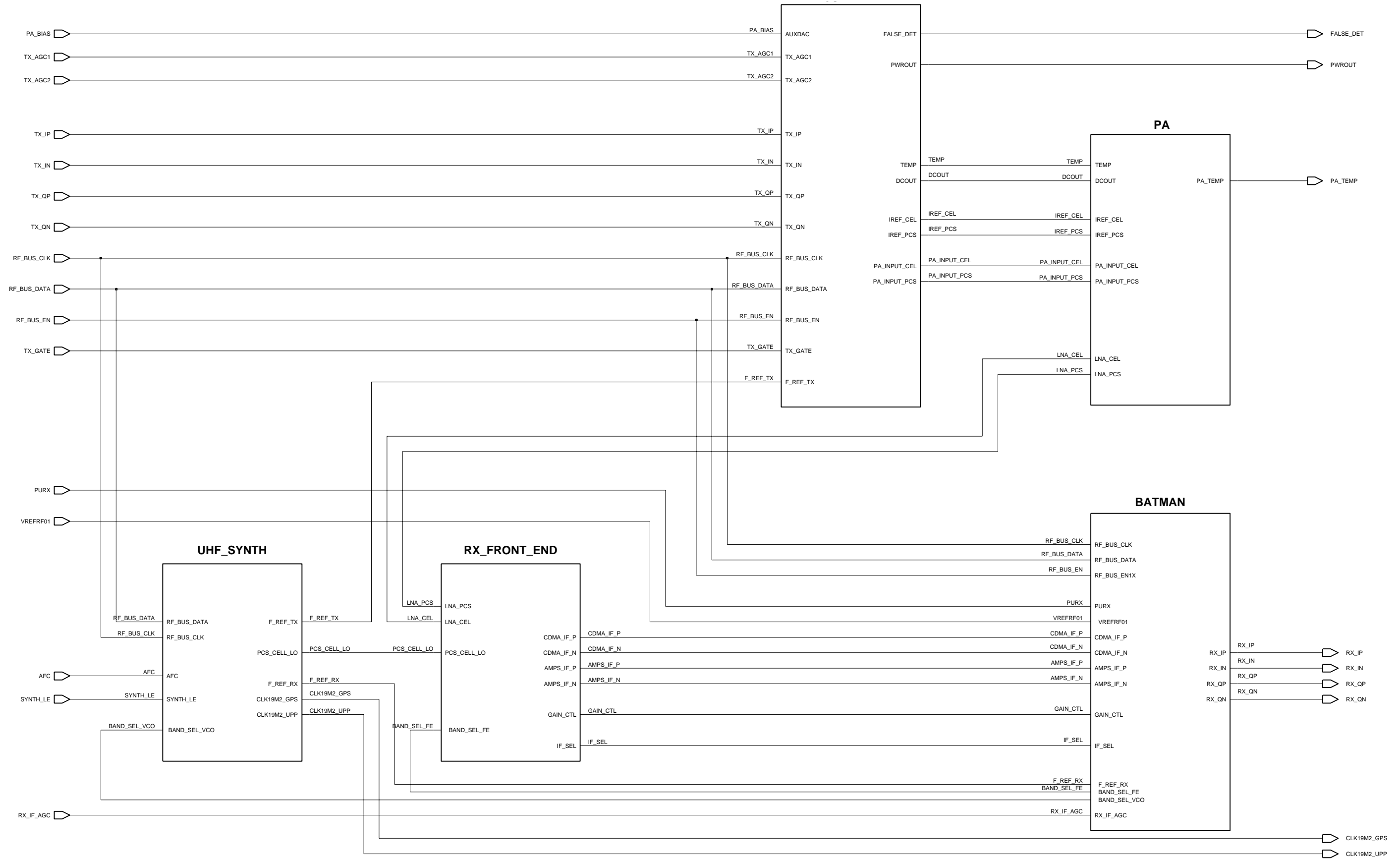

UHF Synthesizer

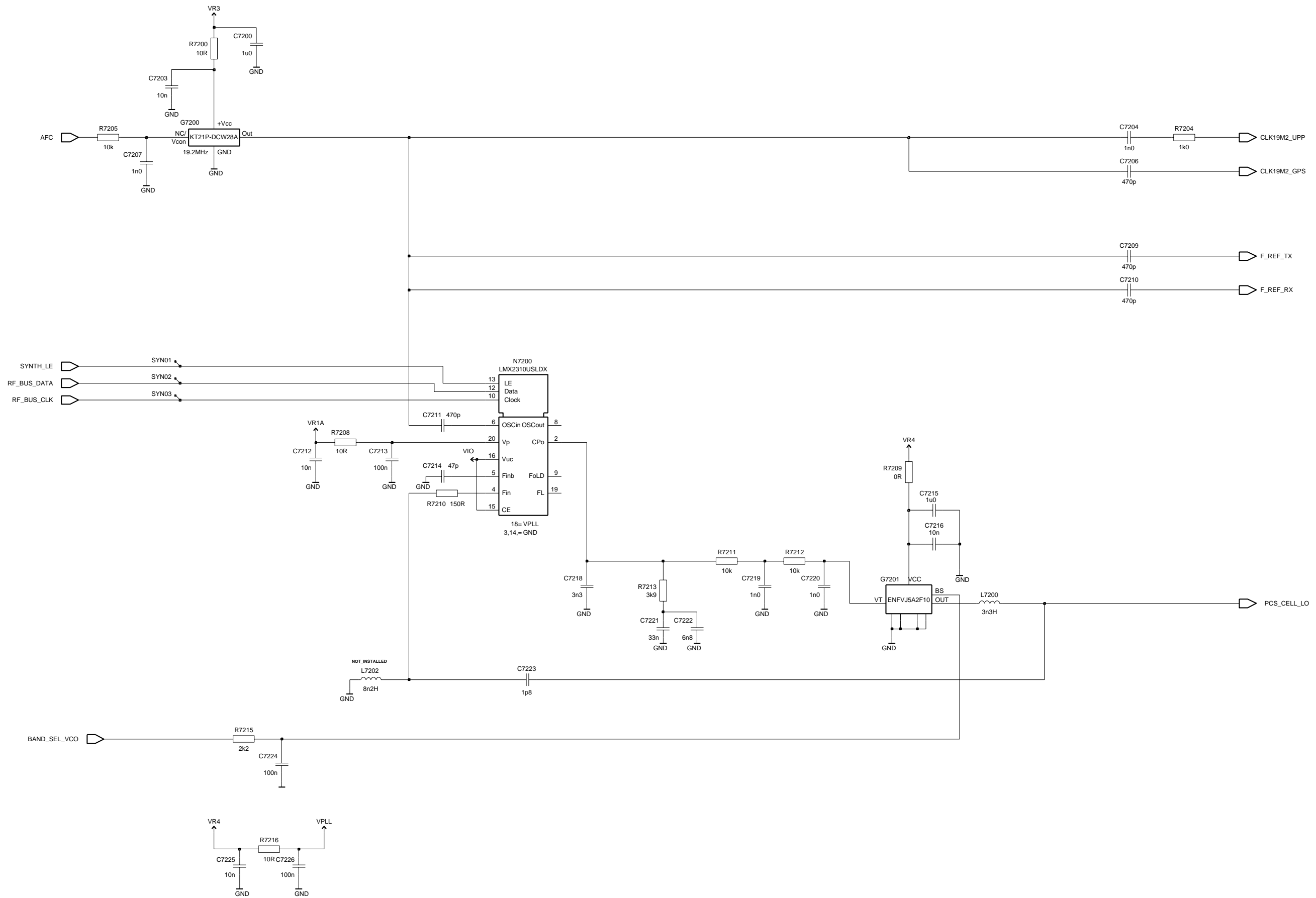

Front End (N7160)

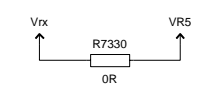
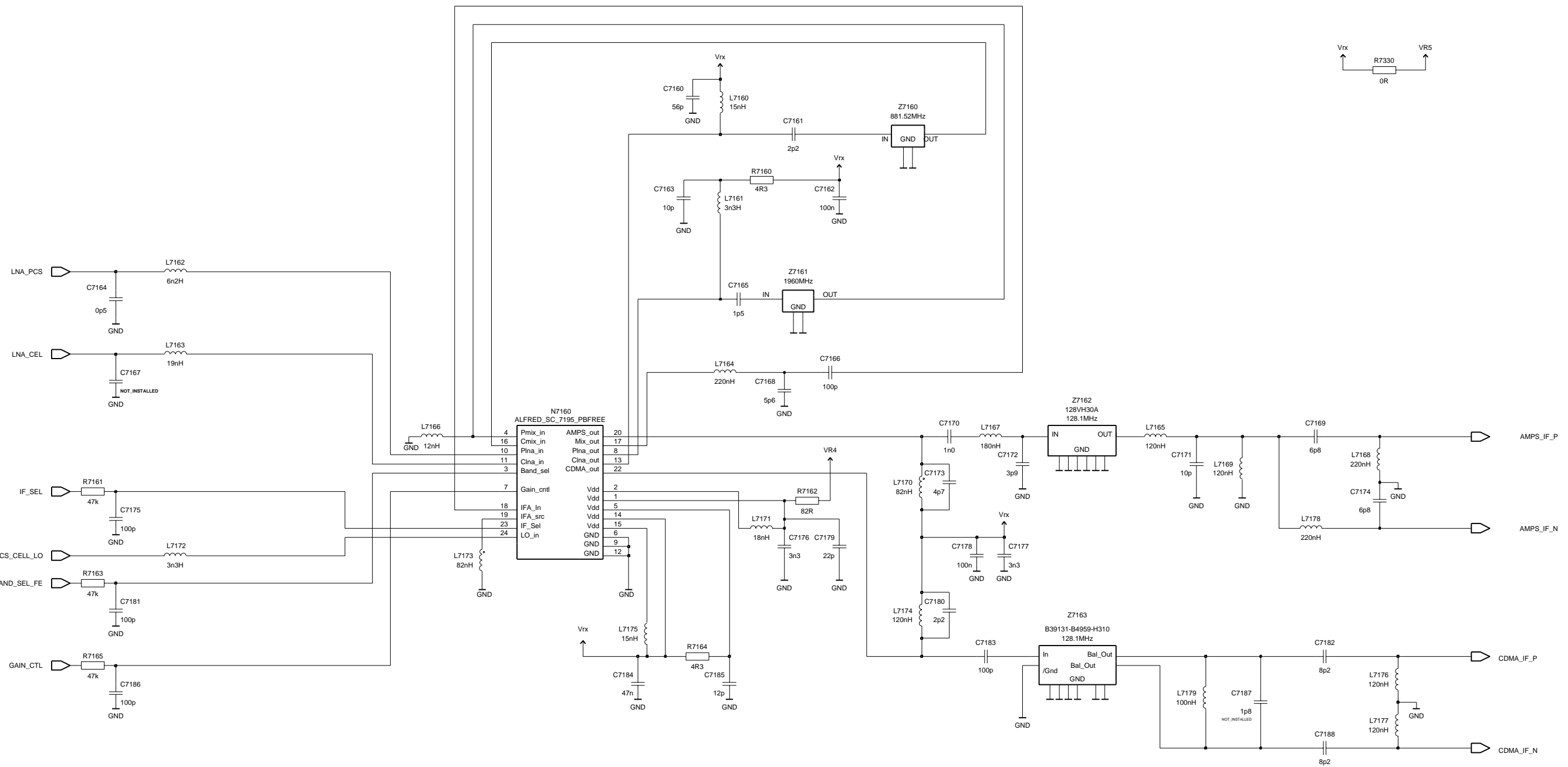

| MODES | LOGIC INPUTS | | |
|------------------|--------------|----------|--------|
| | BAND | GAIN_CTL | IF_SEL |
| CEL CDMA Hi Gain | 0 | 1 | 0 |
| CEL CDMA Lo Gain | 0 | 0 | 0 |
| PCS CDMA Hi Gain | 1 | 1 | 0 |
| PCS CDMA Lo Gain | 1 | 0 | 0 |
| AMPS Hi Gain | 0 | 1 | 1 |
| AMPS Lo Gain | 0 | 0 | 1 |

N7000

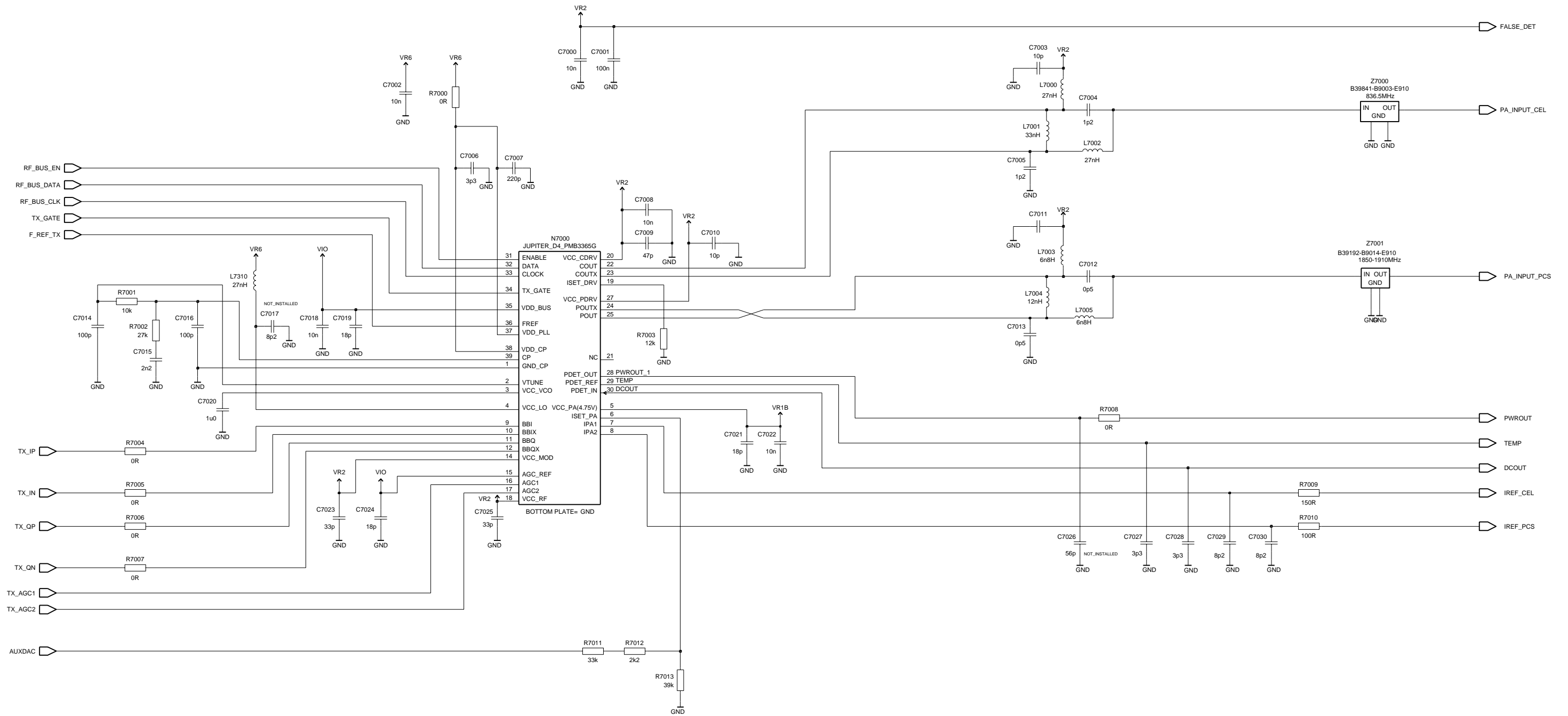

PA

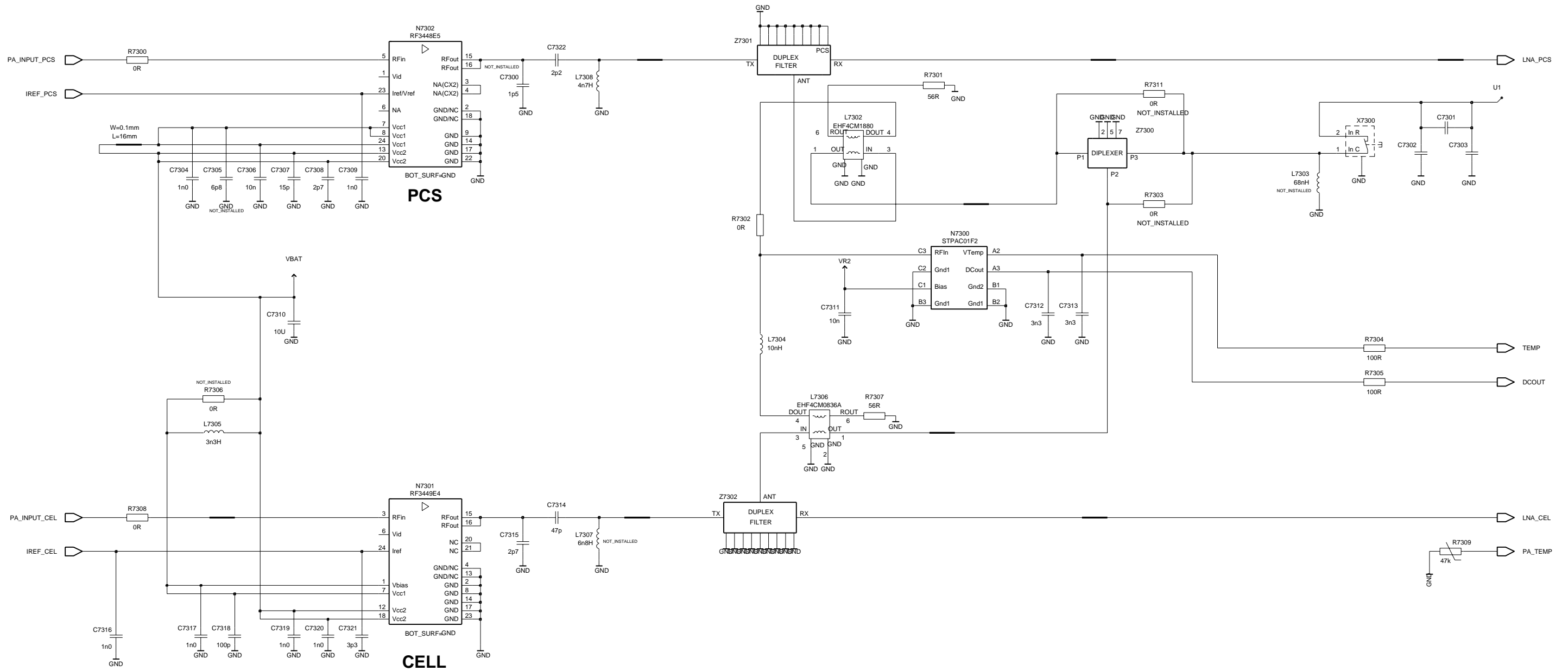

N7100

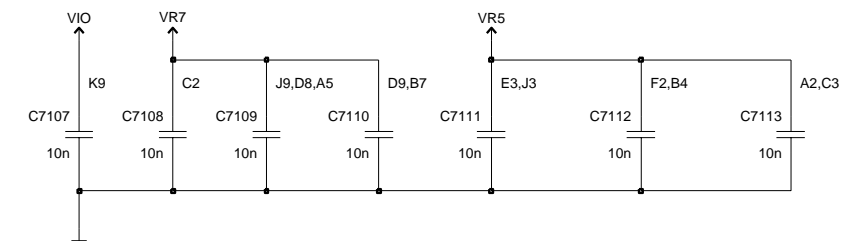
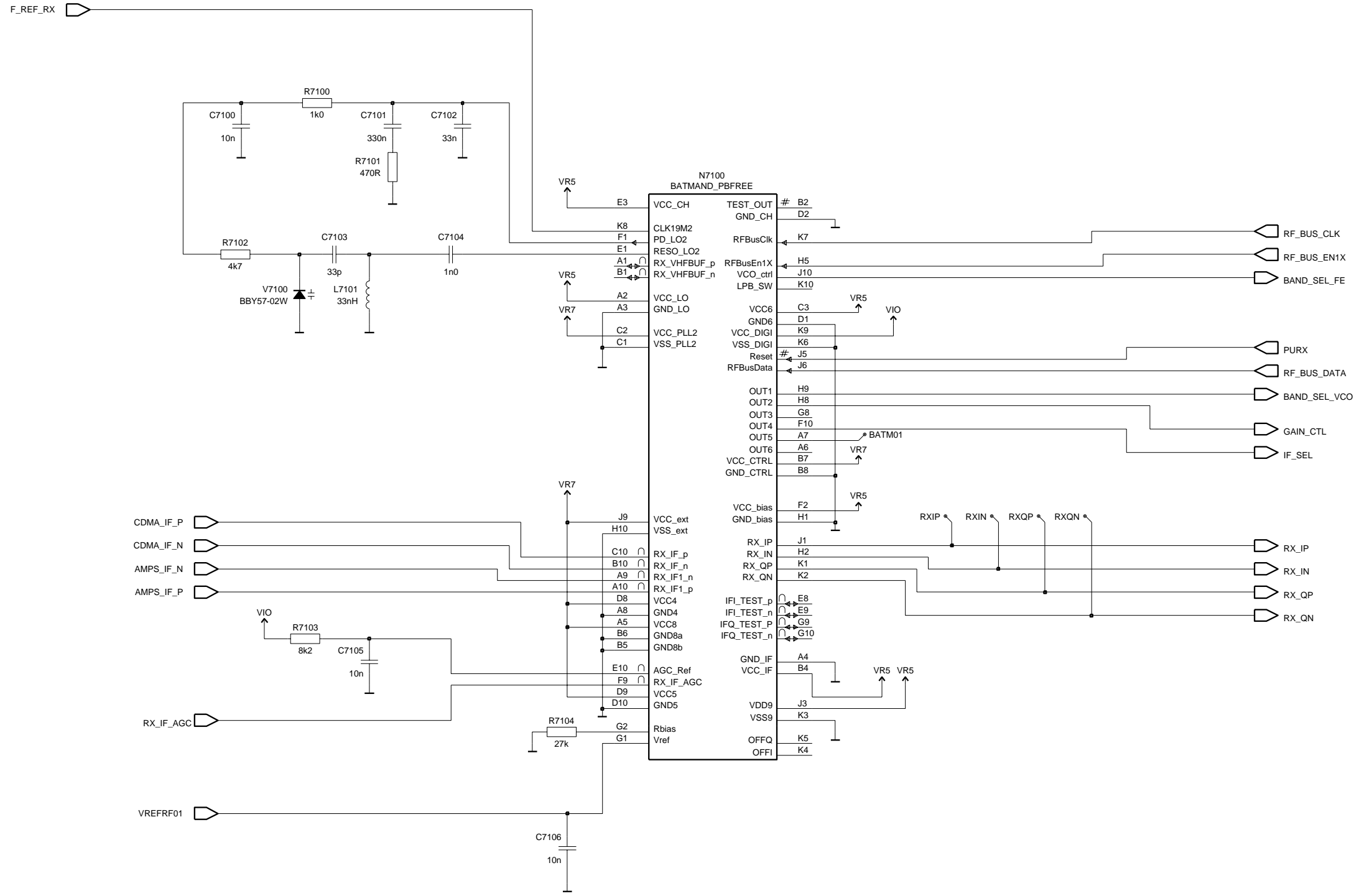

GPS RF-BB Top Level (2115i and 2116i only)

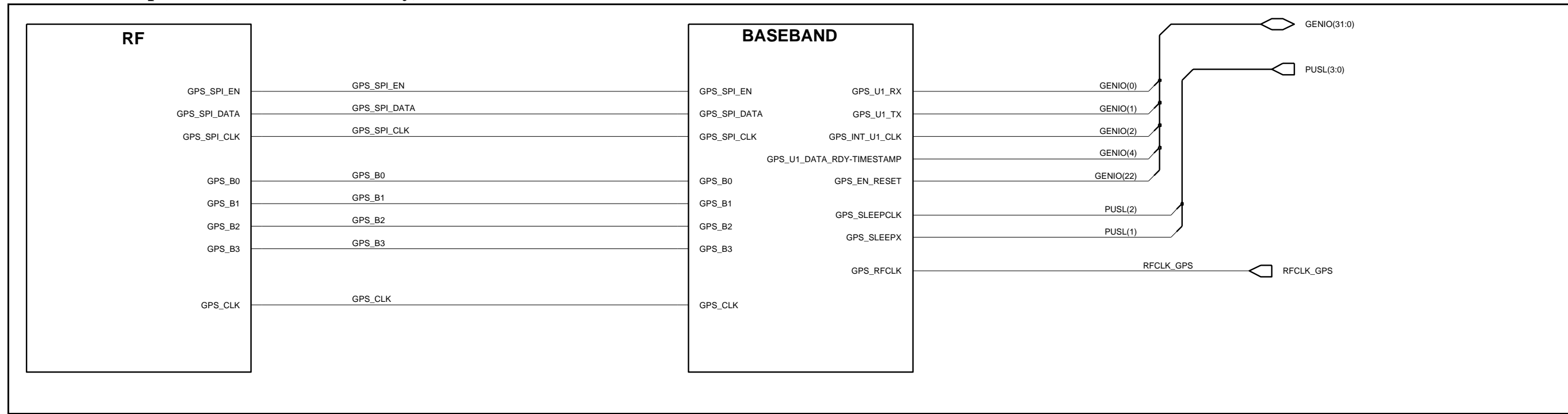

GPS RF (2115i and 2116i only)

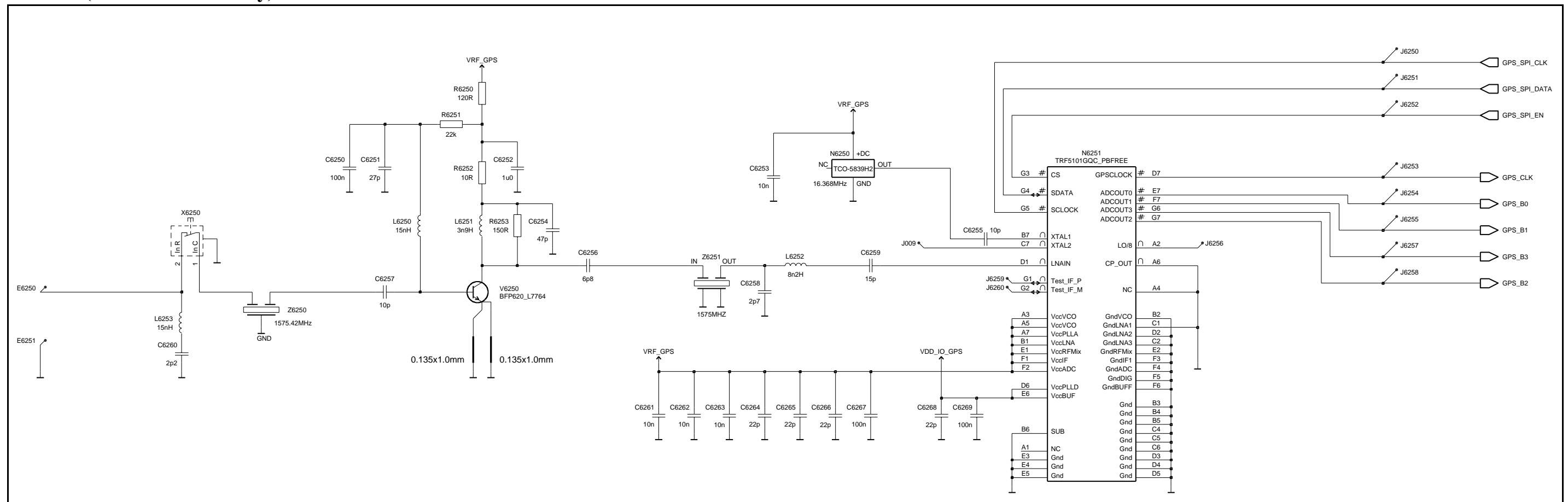

GPS Baseband (2115i and 2116i only)

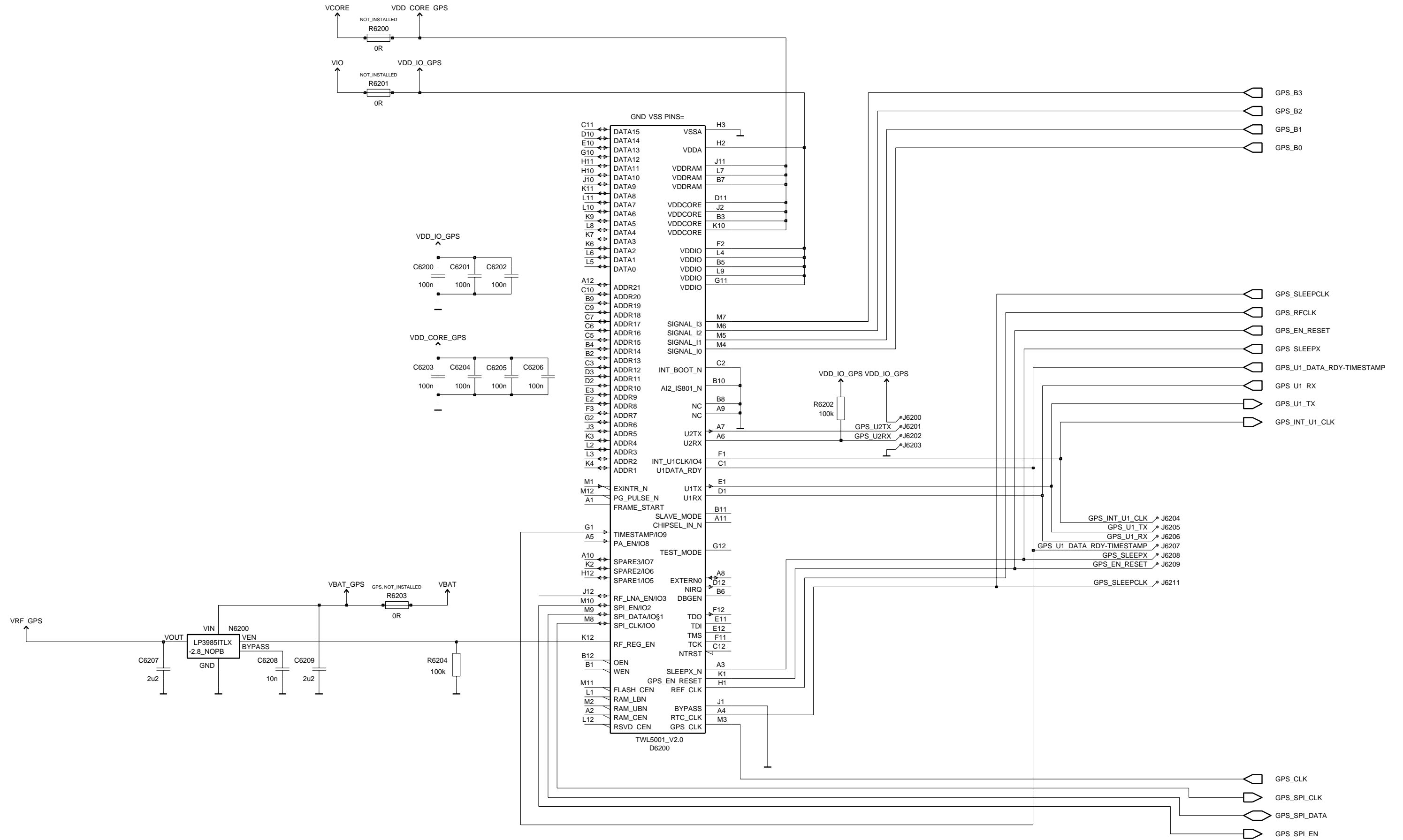

2115i/2116i Component Layout - Top

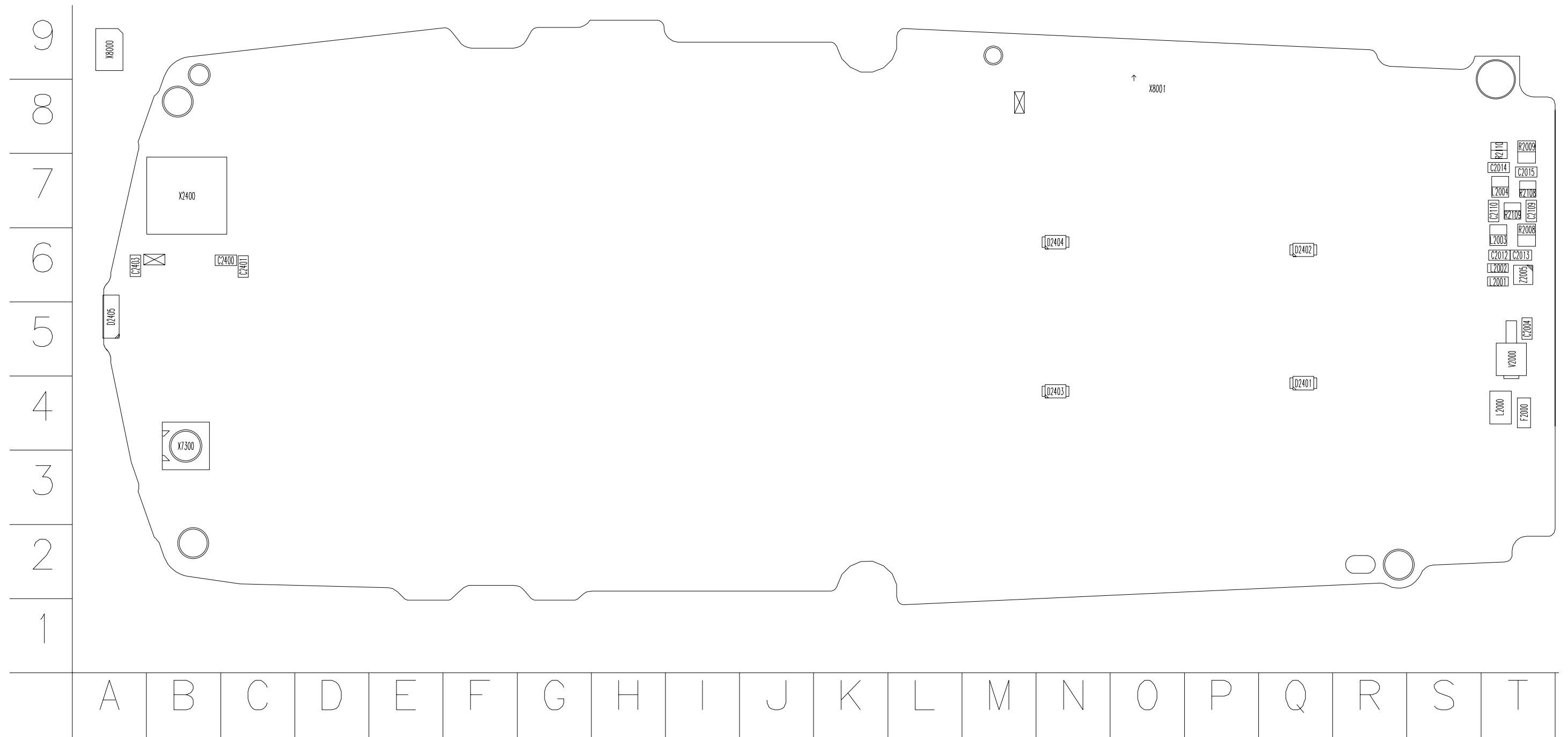

2115i/2116i Component Layout - Bottom

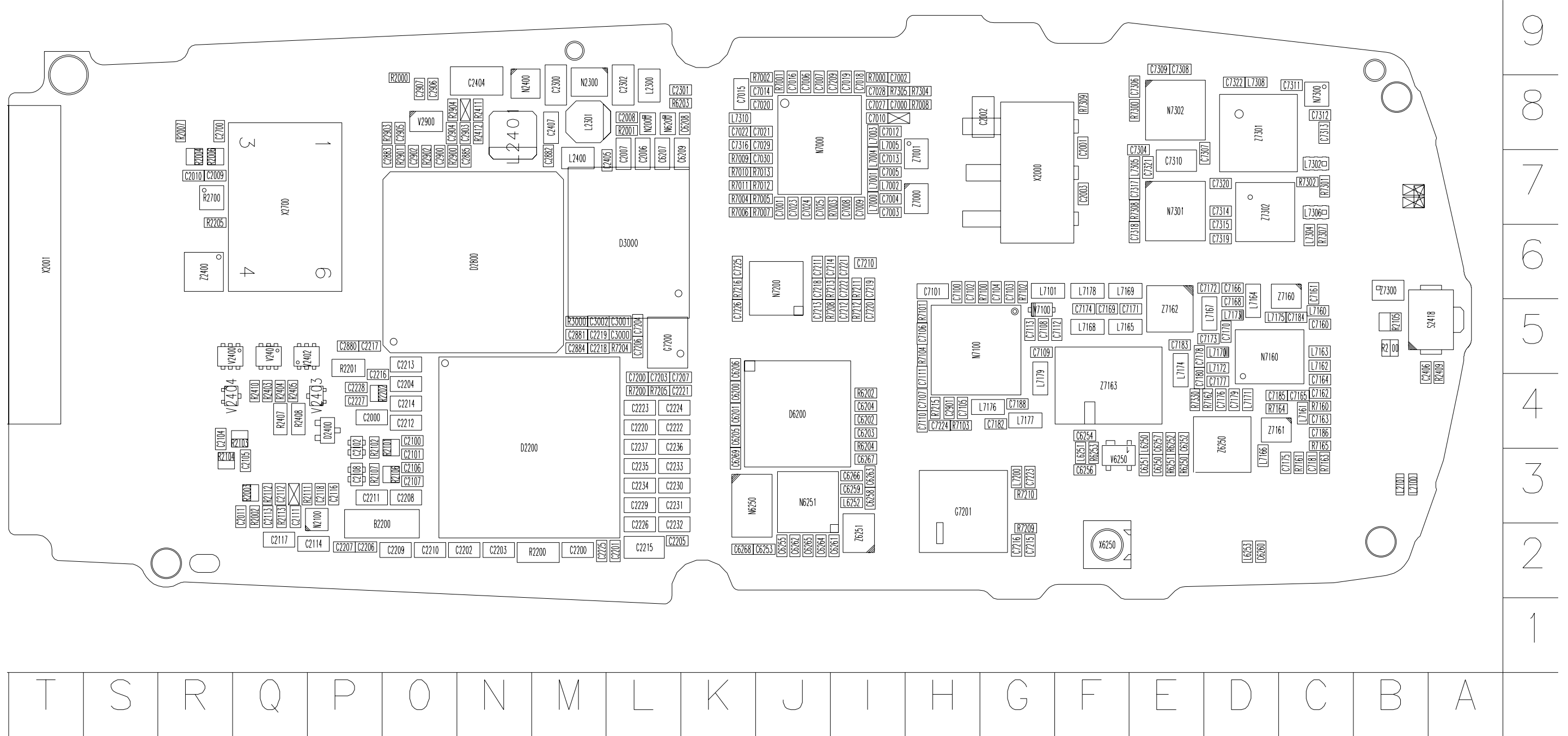

2116 Component Layout - Top

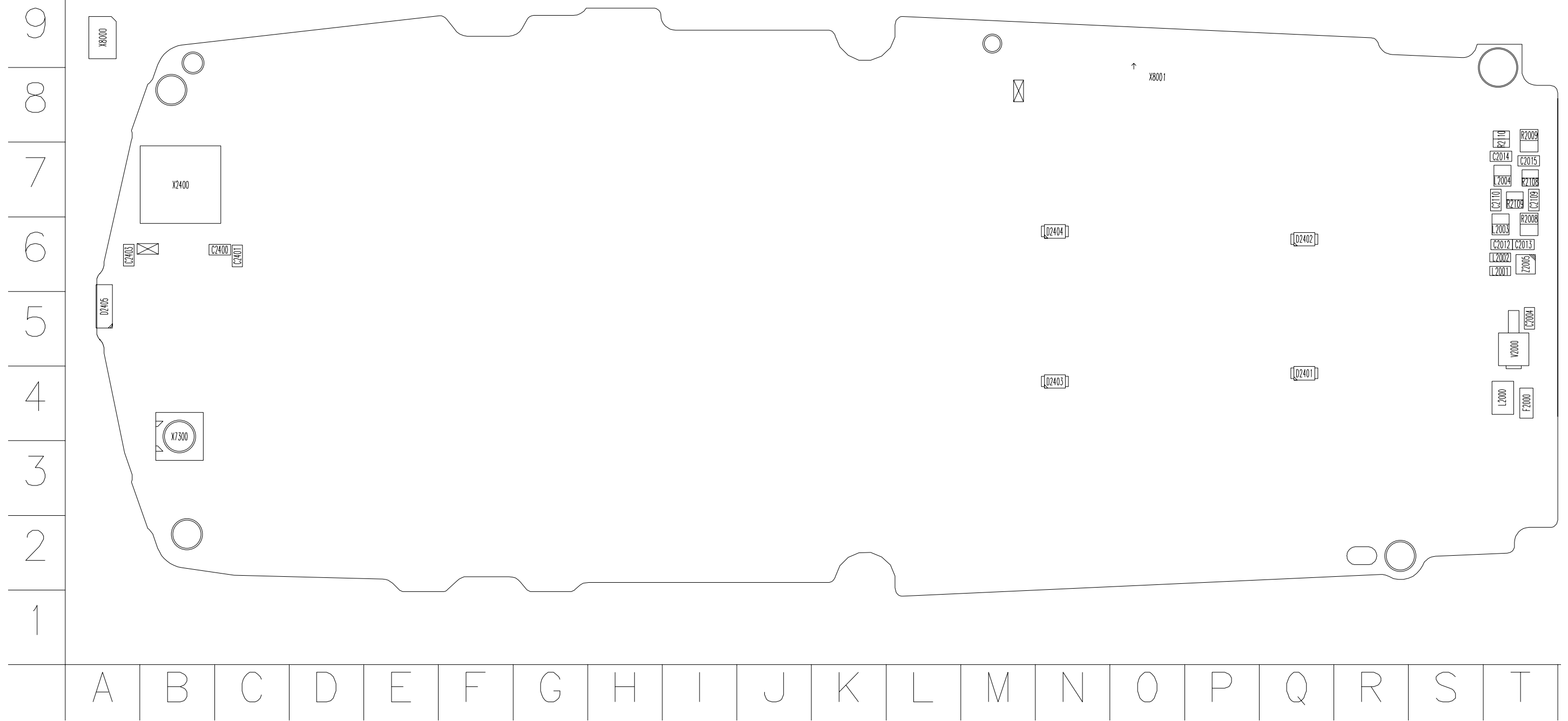

This page intentionally left blank.